

CENTRAL PNEUMATIC®

BRAD NAILER / STAPLER 2-IN-1 KIT

Model 44923

ASSEMBLY AND OPERATION INSTRUCTIONS

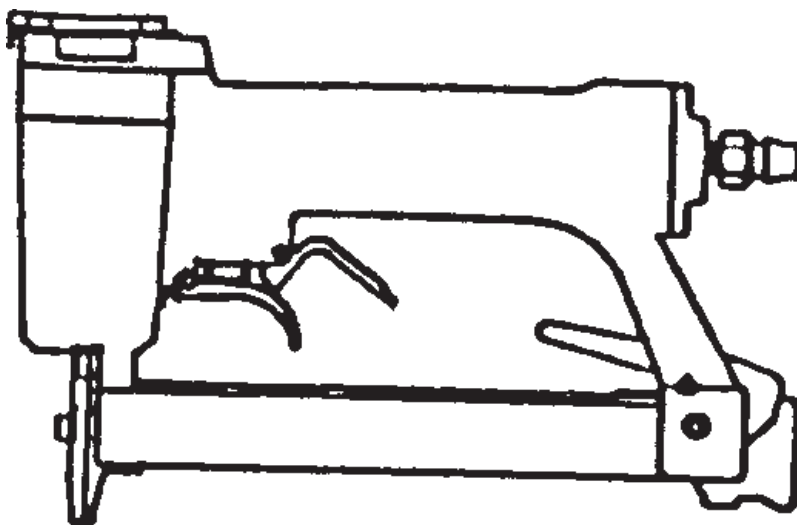

3491 Mission Oaks Blvd., Camarillo, CA 93011

Visit our Web site at <http://www.harborfreight.com>

**TO PREVENT SERIOUS INJURY,
READ AND UNDERSTAND ALL WARNINGS
AND INSTRUCTIONS BEFORE USE.**

Copyright© 2001, 2004 by Harbor Freight Tools®. All rights reserved. No portion of this manual or any artwork contained herein may be reproduced in any shape or form without the express written consent of Harbor Freight Tools.

For technical questions and replacement parts, please call 1-800-444-3353

Specifications

Staple Capacity	$\frac{3}{16}$ " Crown., .034" Thick (20 ga.), $\frac{3}{8}$ - $\frac{5}{8}$ " Long
Included Staples	20 ga., $\frac{5}{8}$ " Long, $\frac{3}{16}$ " Crown (Qty. = 800)
Brad Capacity	.039-.042" Dia. (18 ga.), $\frac{5}{8}$ -1- $\frac{3}{16}$ " Long
Included Brads	18 ga., $\frac{3}{4}$ ", 1", and 1- $\frac{3}{16}$ " Long (Qty. = 800 Each)
Replacement Brads	SKU 33205 - 18g $\frac{3}{4}$ " long; SKU 33206 - 18g 1" long; SKU 33207 - 18g 1- $\frac{3}{16}$ " long
Magazine Capacity	100
Operating PSI	60-100 PSI
Air Inlet Size	$\frac{1}{4}$ " NPT
Safety Feature	Double Trigger
CFM	8 @ 90 PSI
Accessories	3 mm & 4 mm Hex Keys, Inlet Coupler Plug, Lubricating Oil

Save This Manual

You will need the manual for the safety warnings and precautions, assembly instructions, operating and maintenance procedures, parts list and diagram. Keep your invoice with this manual. Write the invoice number on the inside of the front cover. Keep the manual and invoice in a safe and dry place for future reference.

Safety Warnings and Precautions



WARNING: When using tool, basic safety precautions should always be followed to reduce the risk of personal injury and damage to equipment.

Read all instructions before using this tool!

1. **Keep work area clean.** Cluttered areas invite injuries.
2. **Observe work area conditions.** Do not use machines or power tools in damp or wet locations. Do not expose to rain. Keep work area well lit. Do not use electrically powered tools in the presence of flammable gases or liquids.
3. **Keep children away.** Children must never be allowed in the work area. Do not let them handle machines, tools, extension cords, or air hoses.
4. **Store idle equipment.** When not in use, tools must be stored in a dry location to inhibit rust. Always lock up tools and keep out of reach of children.
5. **Use the right tool for the job.** Do not attempt to force a small tool or attachment to do the work of a larger industrial tool. There are certain applications for which this tool was designed. It will do the job better and more safely at the rate for which it was intended. Do not modify this tool and do not use this tool for a purpose for which it was not intended.
6. **Dress properly.** Do not wear loose clothing or jewelry as they can be caught in moving parts. Protective, electrically non-conductive clothes and non-skid footwear are recommended when working. Wear restrictive hair covering to contain long hair.
7. **Do not overreach.** Keep proper footing and balance at all times. Do not reach over or across running machines or air hoses.

8.



Use eye and ear protection. Always wear ANSI approved impact safety goggles and appropriate hearing protection. Wear a full face shield if you are producing metal filings or wood chips. Wear an ANSI approved dust mask or respirator when working around metal, wood, and chemical dusts and mists. Other people in the work area must also wear ANSI approved impact safety goggles.

9. **Maintain tools with care.** Keep tools clean for better and safer performance. Follow instructions for lubricating and changing accessories. Inspect tool cords and air hoses periodically and, if damaged, have them repaired by an authorized technician. The handle must be kept clean, dry, and free from oil and grease at all times. Do not operate a tool if any portion of the tool's operating controls are inoperable, disconnected, altered or not working properly.
10. **Disconnect Air Hose and release any built-up air pressure.** Never service the Nailer, clear jams, or disassemble with the air hose attached. Always release any built-up air even after disconnecting hose. Disconnect the Nailer when not in use.
11. **Remove adjusting keys and wrenches.** Check that keys and adjusting wrenches are removed from the tool or machine work surface before attaching to an air source.
12. **Avoid unintentional starting.** Be sure the trigger is in the Off position when not in use and before plugging in. Do not carry any tool with your finger on the trigger, whether it is attached to an air source or not. Do not point the tool towards yourself or anyone whether it contains fasteners or not.
13. **Stay alert.** Watch what you are doing, use common sense. Do not operate any tool when you are tired.
14. **Check for damaged parts.** Before using any tool, any part that appears damaged should be carefully checked to determine that it will operate properly and perform its intended function. Check for alignment and binding of moving parts; any broken parts or mounting fixtures; and any other condition that may affect proper operation. Any part that is damaged should be properly repaired or replaced by a qualified technician. Do not use the tool if the trigger does not operate properly.
15. **Guard against electric shock.** Prevent body contact with grounded surfaces such as pipes, radiators, ranges, and refrigerator enclosures.
16. **Replacement parts and accessories.** This product is to be repaired and serviced only by a qualified technician. When this product is serviced, only identical replacement parts should be used. Use of any other parts will void the warranty. Only use accessories intended for use with this tool. Approved accessories are available from Harbor Freight Tools.
17. **Do not operate tool if under the influence of alcohol or drugs.** Read warning labels if taking prescription medicine to determine if your judgement or reflexes are impaired while taking drugs. If there is any doubt, do not operate the tool.
18. **Use proper size and type extension cord.** If an extension cord is required, it must be of the proper size and type to supply the correct current to the compressor without heating up. Otherwise, the extension cord could melt and catch fire, or cause electrical damage to the tool. Check your air compressor's manual for the appropriate size cord. It is also possible that the use of an extension cord may cause your circuit breaker to trip or your

panel fuse to break. If this happens, either use the compressor without an extension cord or find a larger amperage circuit to use.

19. **Maintenance.** The maintenance outlined in the maintenance section should be performed regularly. For your safety, this product should be serviced or repaired regularly only by a qualified technician.

20. **Compressed air only.** Never use combustible gas as a power source.

21.  **Do not load nails with the trigger or safety depressed.** Unintentional firing may occur. Do not load nails when the air hose is connected to the tool. Always assume that the tool contains fasteners.

22. **Disconnect air supply before loading Nailer.** Before reloading (or making any adjustments to) the Nailer make sure that the compressed air is disconnected.

23. **Fire fasteners into an appropriate work surface only.** Do not attempt to fire fasteners into surfaces too hard to penetrate. Do not drive fasteners on top of other fasteners, or at too steep of an angle. Fasteners can ricochet causing personal injury. Never fire the Nailer into the air, or point it toward yourself or another person. Always wear ANSI approved safety goggles during use, maintenance, and reloading.

24. **Do not fire fasteners too close to the edge of a workpiece.** They may split the workpiece and fly free, causing personal injury.

25. **Take caution as some woods contain preservatives such as copper chromium arsenate (CCA) which can be toxic.** When stapling or nailing these materials extra care should be taken to avoid inhalation and minimize skin contact.

WARNING: Some dust created by power sanding, sawing, grinding, drilling, and other construction activities, contain chemicals known [to the State of California] to cause cancer, birth defects or other reproductive harm.

Some examples of these chemicals are:

- Lead from lead-based paints
- Crystalline silica from bricks and cement or other masonry products
- Arsenic and chromium from chemically treated lumber

(California Health & Safety Code 25249.5, et seq.)

26. **Stay within air pressure capacity.** Never operate the Nailer above 100 PSI.

27. **Hold tool away from head and body.** During operation the Nailer may kick back causing injury.

28. **Transport Nailer safely.** Always disconnect air supply when moving the tool in the workplace. Carry the tool by the handle and avoid contact with the trigger.

Note: Performance of the compressor (if powered by line voltage) may vary depending on variations in local line voltage. Extension cord usage may also affect tool performance.

Warning: The warnings, cautions, and instructions discussed in this instruction manual cannot cover all possible conditions and situations that may occur. It must be understood by the operator that common sense and caution are factors which cannot be built into this product, but must be supplied by the operator.

Unpacking

When unpacking, check to make sure the parts listed on page 9 are included. If any parts are missing or broken, please call Harbor Freight Tools at the number on the cover of this manual as soon as possible.

Operation

For best service, you should incorporate an oiler, regulator, and inline filter, as shown in the diagram below. Hoses, couplers, oilers, regulators, and filters are all available at Harbor Freight Tools.

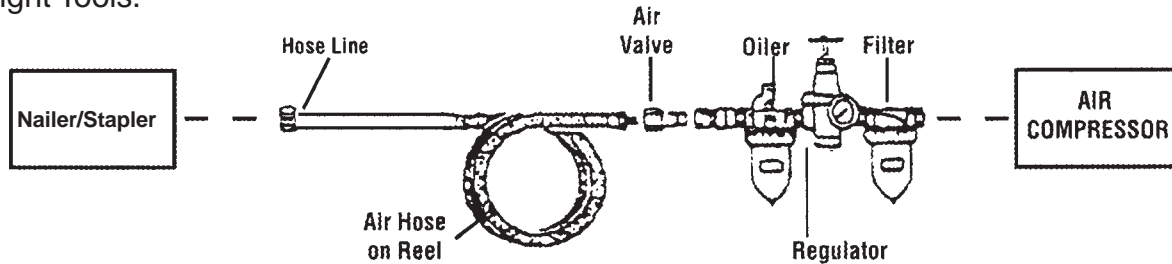

Recommended Air Line Components

Note: To connect this tool, we recommend a quick coupler/adaptor (not included). Coupler/adaptors are available at Harbor Freight Tools. For smoother operation, put 3-5 drops of pneumatic tool oil in the Air Inlet (122) before each use.

Testing the Double Trigger Safety Mechanism

Warning: Even though the nailer should be empty during this procedure, **ALWAYS** point the nailer at a piece of scrap wood when testing.

1. Make sure the tool is disconnected from the power supply.
2. Completely empty the magazine of nails.
3. The Nailer should not fire if the second trigger is not pulled.
4. Check that the Trigger (125) and the Safety Trigger (123) move freely, without sticking - see Figure 1.
5. Connect the air supply to the tool at the Air Inlet (122) set at the recommended 60-100 PSI, and not to go over the maximum 100 PSI.
6. Hold the tool against the workpiece. Squeeze the Safety Trigger (123) and release it. The Safety Trigger should return to its original position. Squeeze the Trigger (125). **The tool should not cycle (fire).** If it cycles (fires), stop immediately and take the tool to an authorized service technician.
7. Squeeze the Safety Trigger (123) and then the Trigger (125). **The tool must cycle (fire).** If it fails to cycle (fire), take it to an authorized service technician.

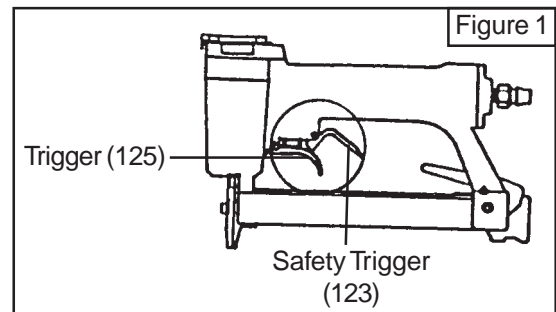

Loading Staples



ALWAYS WEAR ANSI APPROVED IMPACT SAFETY GOGGLES WHEN RELOADING OR DOING ANY OTHER MAINTENANCE ON THIS TOOL. Other people in the work area must also wear ANSI approved impact safety goggles.

Warning! Make sure the Nailer is not attached to the air hose whenever loading the tool.

1. The Nailer/Stapler should be in the same position as in Figure 2.
2. As in Figure 3, depress Magazine Lock (229) and slide Magazine Cover (227) open.
3. Slide the staples over the Magazine's Core (216) (see Figure 4).
4. After the staples reach the nose of the tool, close the Magazine Cover (see Figure 5).

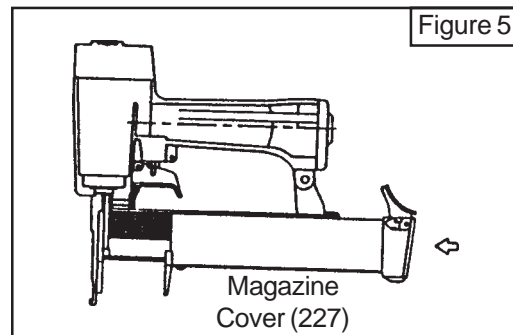
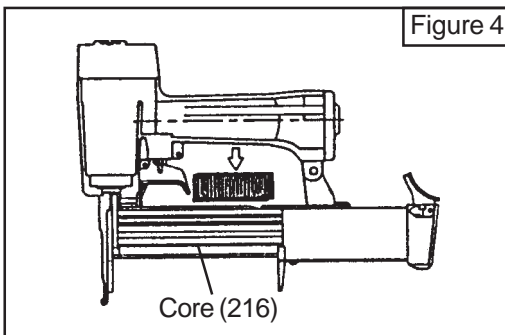
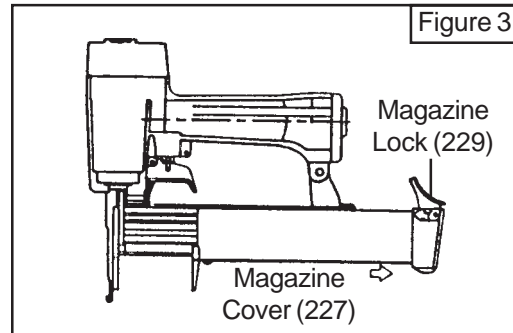
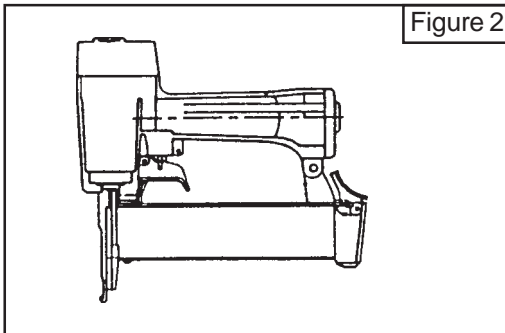

Loading Brad Nails



ALWAYS WEAR ANSI APPROVED IMPACT SAFETY GOGGLES WHEN RELOADING OR DOING ANY OTHER MAINTENANCE ON THIS TOOL. Other people in the work area must also wear ANSI approved impact safety goggles.

Warning! Make sure the Nailer is not attached to the air hose whenever loading the tool.

1. Follow *Loading Staples* steps 1 and 2, above.
2. Insert the Brad Nails into the Magazine, letting the pointed end ride on the rail along the bottom of the Magazine (205) (see Figures 4 and 6).
3. After the Nails reach the nose of the tool, close the Magazine Cover (227) (see Figure 6, below).

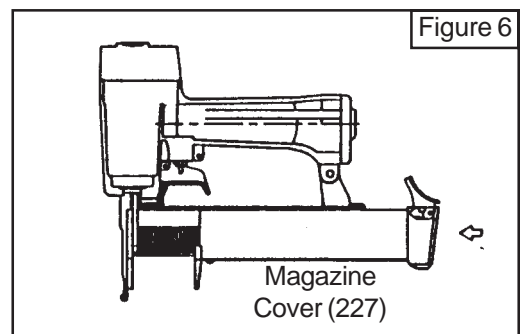

Operating the Nailer

1. Attach the Nailer to the air supply at the Air Inlet (122). Start your compressor and check the pressure making sure it is set at the recommended 60-100 PSI and not to go over the maximum 100 PSI.
2. To fire, place the nose of the Nailer on the workpiece. The Nailer should not fire if the Safety Trigger (123) is not depressed. Once depressed, gently and briefly squeeze the Trigger (125) once. **Do not fire repeatedly.** Nails could bounce off of one another, damaging the work piece or causing PERSONAL INJURY.

Note: When using Brad Nails, the Driver Guide (206) might leave a slight mark on the surface of the workpiece which is larger than the nail brad. It occurs normally because the Driver Guide (206) tip is slightly wider to accommodate staples.

To help avoid this, angle the tool slightly as shown in Figure 7.

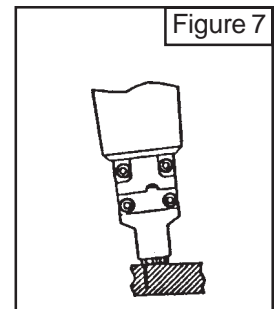

Anytime *any* maintenance or repairs are done (including clearing jams), FIRST:

1. Disconnect the Nailer from the air hose.
2. Empty the Magazine (205) completely.
3. Attempt to fire the Nailer into a piece of scrap wood to ensure that it is disconnected and is incapable of firing any brads.
4. **Always leave the Magazine Cover (227) open during maintenance. The Magazine is spring-loaded and may cause parts or a nail to fly out of the Nailer.**

Clearing Jams

1. Disconnect tool from air hose, empty the Magazine (205) of nails, release any built-up air pressure, and leave the magazine open, as explained above.
2. While doing this step and the next, hold the Nailer pointed away from you and any other people or fragile objects - see Figure 8. Loosen both Cover Hex Bolts (234) on Driver Guide Cover C (233) 3/4 of a turn each - see Figure 9.
3. Slide Driver Guide Cover C (233) toward the nose of the Nailer slightly until the holes (See Figure 9.) in Driver Guide Cover C (233) line up with the heads of both Cover Hex Bolts (234).
4. Carefully remove Driver Guide Cover C (233) and remove the jammed nail. Pliers may be necessary to remove a stuck nail.

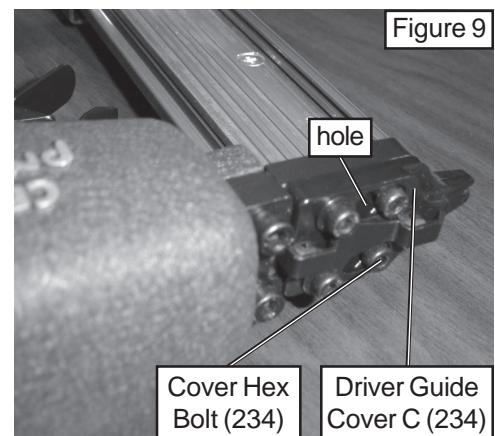
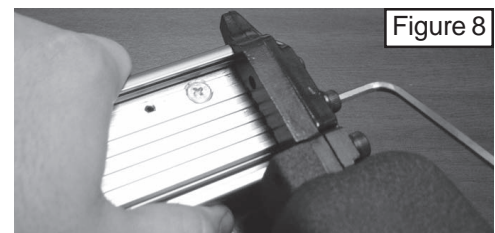

Clearing Jams (continued)

5. Inspect the Driver (114) for bends or breakage - see Figure 10. If it is not fully retracted or damaged, do not use the tool until it is repaired by a qualified technician.
6. Lightly oil the Driver (114) and replace Driver Guide Cover C (233). Slide Driver Guide Cover C (233) away from the nose of the Nailer until the shafts of the Cover Hex Bolts (234) fit into the slots in the Cover. Tighten both Cover Hex Bolts (234) securely.
7. Reload the Nailer.
8. Reconnect the Nailer to the air hose.
9. Press the nose of the Nailer against an appropriate piece of scrap wood.
10. Test fire the Nailer several times, checking for proper operation.
11. Disconnect the Nailer, remove the nails and store Nailer in a location out of children's reach.

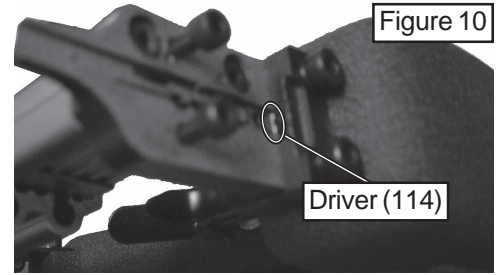

Anytime any maintenance or repairs are done, FIRST:

1. Disconnect the Nailer from the air hose.
2. Empty the Magazine (205) completely.
3. Attempt to fire the Nailer into a piece of scrap wood to ensure that it is disconnected and is incapable of firing any brads.
4. **Always leave the Magazine Cover (227) open during maintenance. The Magazine is spring-loaded and may cause parts or a nail to fly out of the Nailer.**

Maintenance

ANY MAINTENANCE OR REPAIRS ASIDE FROM THAT LISTED BELOW SHOULD ONLY BE PERFORMED BY A QUALIFIED TECHNICIAN.

1. Inspect all of the nuts and screws and make sure they are securely fastened.
2. Periodically lubricate the driving mechanism and magazine with a light oil. Wipe down with a clean cloth.
3. Inspect and clean the Air Filter Regulator and the Air Compressor according to manufacturer's instructions.

Parts List

Part	Description
101	Hex Sec. Bolt
102	Spring Washer
103	Deflector
104	Spring
105	Seal
106	Cap
107	O-ring
108	O-ring
109	Valve Piston
110	O-ring
111	Stopping Ring
112	Collar
113	O-ring
114	Driver
115	O-ring
116	Cylinder
117	Bumper
118	Gun Body
119	Joint Guide
120	Hex Sec. Bolt
121	O-ring
122	Air Inlet
123	Safety Trigger

Part	Description
124	Pin
125	Trigger
126	Long Pin
127	Seal
128	Trigger Valve Head
129	Trigger Valve Head
130	O-ring
131	O-ring
132	Trigger Valve Guide
134	O-ring
201	Hex Sec. Bolt
202	Spring Washer
203	Stopping Bracket
204	Nut
205	Magazine
206	Driver Guide
207	Driver Guide Cover B
208	Spring Washer
209	Hex Sec. Bolt
210	Driver Guide Cover A
211	Spring
212	Flat Bar
213	Hex Sec. Bolt

Part	Description
214	Flat Bar
215	Hex Sec. Bolt
216	Core
217	Pusher
218	Link Block
219	Pusher Spring
220	Spring Washer
221	Nut
222	Bracket
223	Washer
224	Stopper Spring
225	Stopper
226	Rear Plate
227	Magazine Cover
228	O-ring
229	Magazine Lock
230	Pin
231	Spring Washer
232	Hex Sec. Bolt
233	Driver Guide Cover C
234	Cover Hex Bolt

PLEASE READ THE FOLLOWING CAREFULLY

THE MANUFACTURER AND/OR DISTRIBUTOR HAS PROVIDED THE PARTS DIAGRAM IN THIS MANUAL AS A REFERENCE TOOL ONLY. NEITHER THE MANUFACTURER NOR DISTRIBUTOR MAKES ANY REPRESENTATION OR WARRANTY OF ANY KIND TO THE BUYER THAT HE OR SHE IS QUALIFIED TO MAKE ANY REPAIRS TO THE PRODUCT OR THAT HE OR SHE IS QUALIFIED TO REPLACE ANY PARTS OF THE PRODUCT. IN FACT, THE MANUFACTURER AND/OR DISTRIBUTOR EXPRESSLY STATES THAT ALL REPAIRS AND PARTS REPLACEMENTS SHOULD BE UNDERTAKEN BY CERTIFIED AND LICENSED TECHNICIANS AND NOT BY THE BUYER. THE BUYER ASSUMES ALL RISK AND LIABILITY ARISING OUT OF HIS OR HER REPAIRS TO THE ORIGINAL PRODUCT OR REPLACEMENT PARTS THERETO, OR ARISING OUT OF HIS OR HER INSTALLATION OF REPLACEMENT PARTS THERETO.

NOTE: Some parts are listed and shown for illustration purposes only and are not available individually as replacement parts.

Assembly Drawing

